

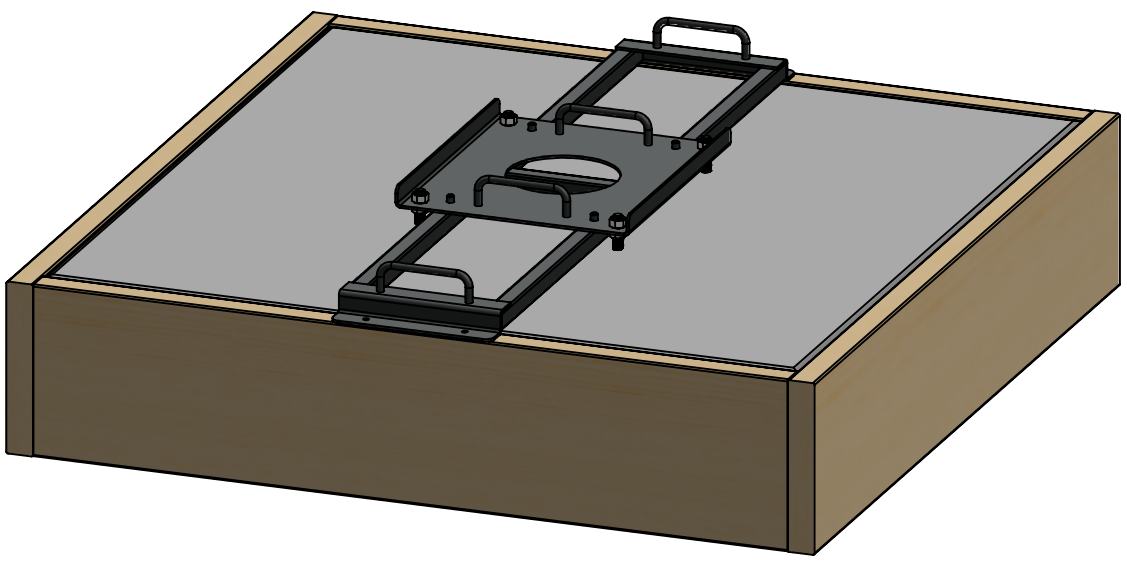

REVISION HISTORY			
REV.	DESCRIPTION	DATE	ECO #
A	RELEASED	11/16/2022	

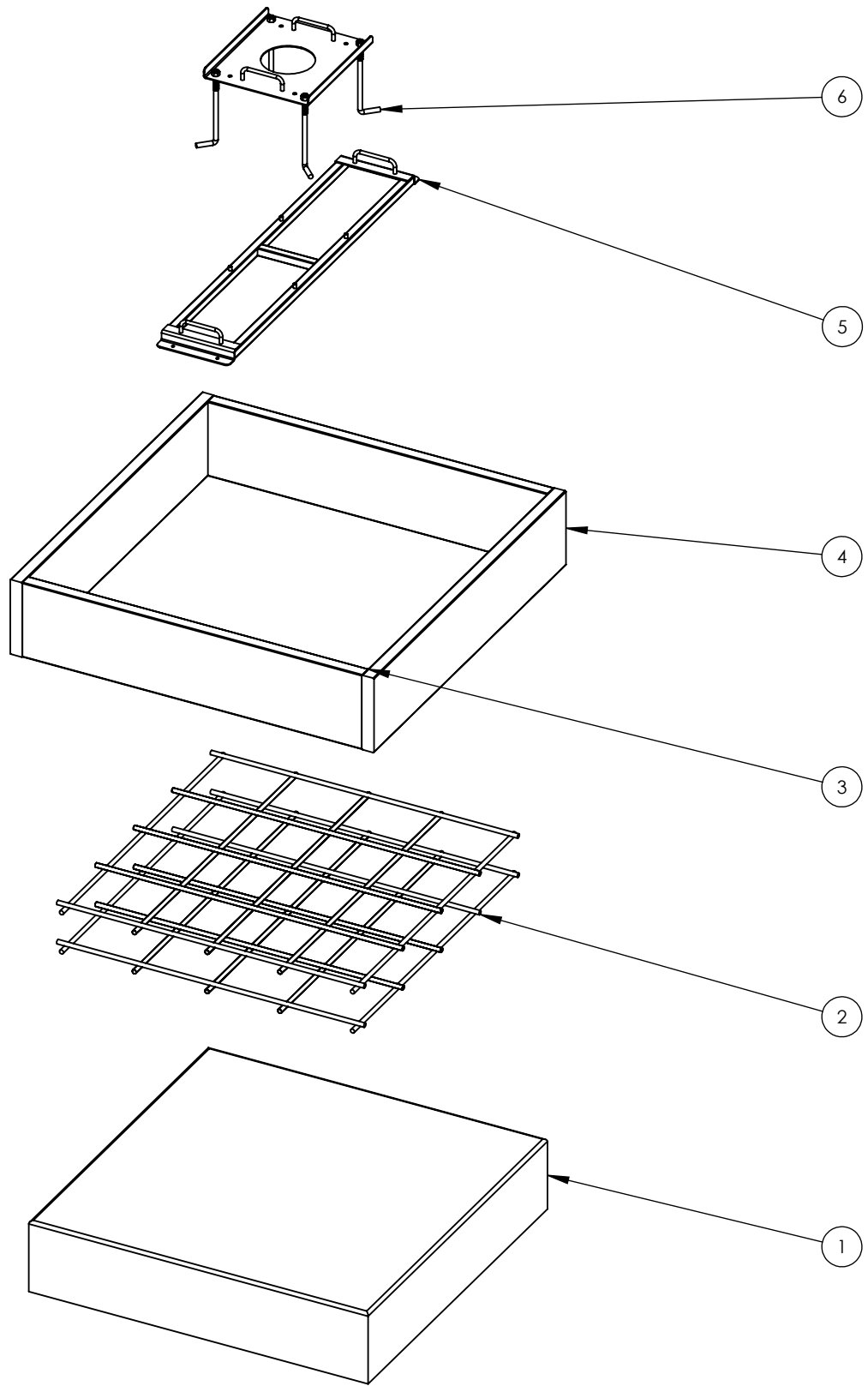

ITEM NO.	PART NUMBER	DESCRIPTION	STOCK SIZE	UOM	QTY.
6	100526	ANCHOR BOLT TEMPLATE		EACH	1
5	100525	TEMPLATE ALIGNMENT SUPPORT		EACH	1
4	FORM WOOD	45" OAL	2X10 FIR WOOD	EACH	2
3	FORM WOOD	42" OAL	2X10 FIR WOOD	EACH	2
2	REBAR PAD #4X9IN	REBAR GRATE, TIED	#4 STEEL REBAR, 9 IN SPACIING	EACH	2
1	CONCRETE PAD	42" X 42" CONCRETE PAD	.34 CUBIC YARD 3500 PSI MIN	EACH	1

PROPRIETARY & CONFIDENTIAL THE INFORMATION CONTAINED IN THIS DRAWING IS THE SOLE PROPERTY OF BLUE STAR TOWERS, LLC. ANY REPRODUCTION WITHOUT WRITTEN CONSENT IS PROHIBITED.	UNLESS OTHERWISE SPECIFIED .X..... ±.030 .XX..... ±.020 .XXX..... ±.010 .XXXX..... ±.005 ANGULAR..... ± 1° FINISH..... 125RA		APPROVALS DRAWN BY: BJH CHECKED BY: ENG APPR.:	NAME: BJH DATE: 11/16/2022	 TITLE:
	THIRD ANGLE PROJECTION 	MATERIAL STOCK SIZE FINISH	INTERPRET PER ASME Y14.5-2009	SCALE: 1:18	
DO NOT SCALE DRAWING			SHEET: 1 OF 3	WEIGHT:	

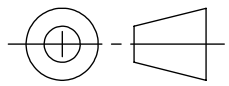
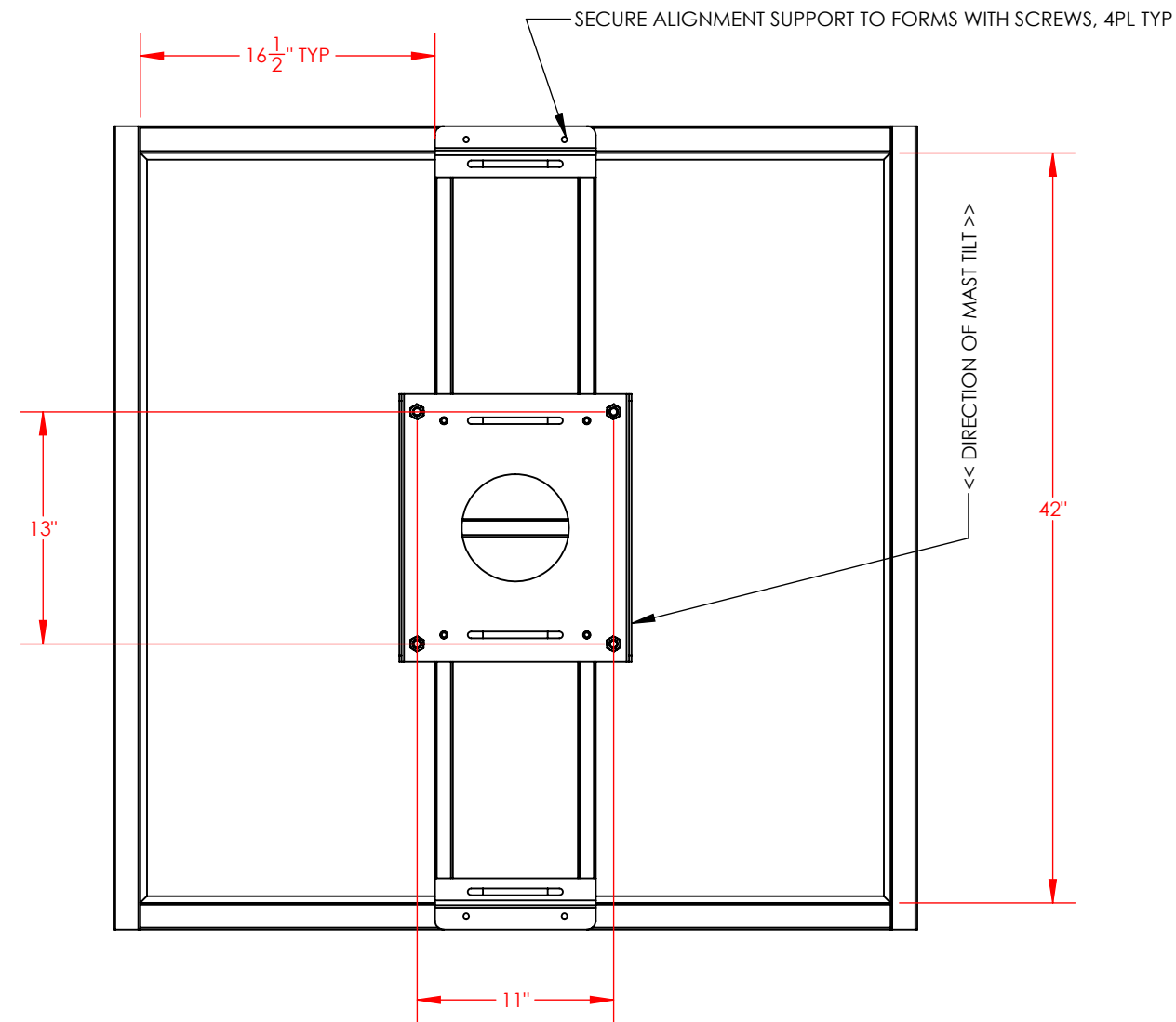

CONCRETE POUR S.O.P.:

1. PREPARE SITE AND WOOD FORMS FOR 42" X 42" X 9" CONCRETE PAD, EMBED CONCRETE IN GROUND MIN 6" DEEP.
2. ADD AND COMPACT GRAVEL IN BOTTOM OF FORM TO ALLOW 9" TO TOP OF FORM.
3. PLACE 1 EACH #4 TIED GRATES ON CHAIR SUPPORTS ON COMPACTED GRAVEL.
4. PLACE 1 EACH #4 REBAR GRATES 5" ABOVE BOTTOM GRATE.
5. MIX AND POUR MINIMUM 3500PSI CONCRETE AS PER ACCEPTED STANDARDS.
6. USE CONCRETE VIBRATOR AS NEEDED AND AS PER ACCEPTED STANDARDS.
7. SCREED, FLOAT, MAG AND CUT CORNERS AS PER CONCRETE POURING STANDARDS.
8. PLACE TEMPLATE ALIGNMENT SUPPORT ON FORM AND CENTER BOTH WAYS.
9. SCREW ALIGNMENT SUPPORT TO FORMS USING PROVIDED HOLES.
10. ENSURE CORRECT DIRECTION OF ALIGNMENT SUPPORT FOR DESIRED LOCATION OF TILT DOWN MAST.
11. BOLT WET SET ANCHOR J-BOLTS TO BOLT TEMPLATE USING HEX NUTS ON BOTH SIDES.
12. ENSURE CORRECT DIMENSION OF BOLT HEAD ABOVE TEMPLATE AS PER PRINT.
13. ALIGN J-BOLTS WITH LEG EXTENDING AT 45 DEGREES OUT FROM TEMPLATE. (4PL TYP)
14. PLACE BOLT TEMPLATE OVER ALIGNMENT PINS ON ALIGNMENT SUPPORT BRACKET.
15. ENSURE J BOLTS ARE EMBEDDED FULLY UNTIL TEMPLATE PLATE RESTS ON SUPPORT.
16. REMOVE ALIGMENT TEMPLATE AFTER CONTRETE IS SET.
17. REMOVE FORMS AND BACK FILL AND COMPACT AS NEEDED.

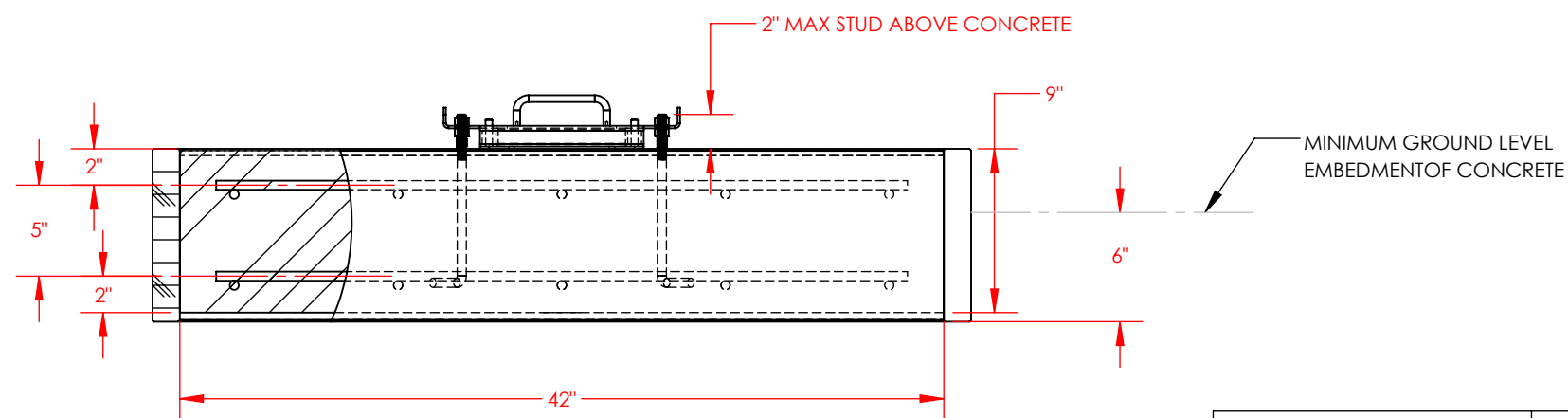

PROPRIETARY & CONFIDENTIAL		UNLESS OTHERWISE SPECIFIED		APPROVALS	NAME	DATE			
THE INFORMATION CONTAINED IN THIS DRAWING IS THE SOLE PROPERTY OF BLUE STAR TOWERS, LLC. ANY REPRODUCTION WITHOUT WRITTEN CONSENT IS PROHIBITED.		.X..... ± .030		DRAWN BY	BJH	11/16/2022			TITLE:
		.XX..... ± .020		CHECKED BY			SIZE		
		.XXX..... ± .010		ENG APPR.			DRAWING NO.		
		.XXX..... ± .005		INTERPRET PER	ASME Y14.5-2009		REV.		
		ANGULAR..... ± 1°		SCALE:	1:10		PAD MOUNT CONCRETE		
		FINISH..... ± 125RA		DO NOT SCALE DRAWING		WEIGHT:		SHEET: 2 OF 3	

8 7 6 5 4 3 2 1

D
C
B
A

D
C
B
A

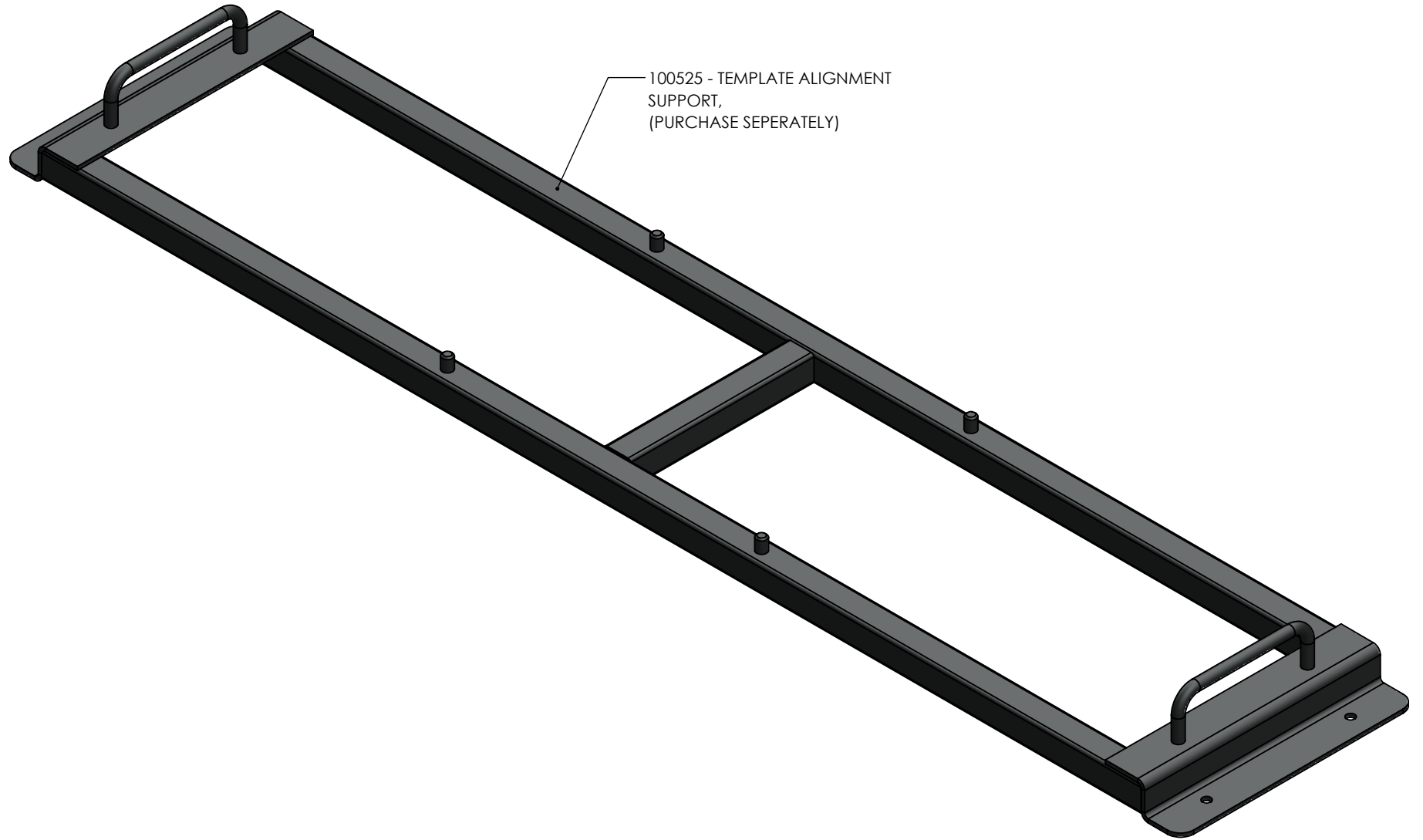
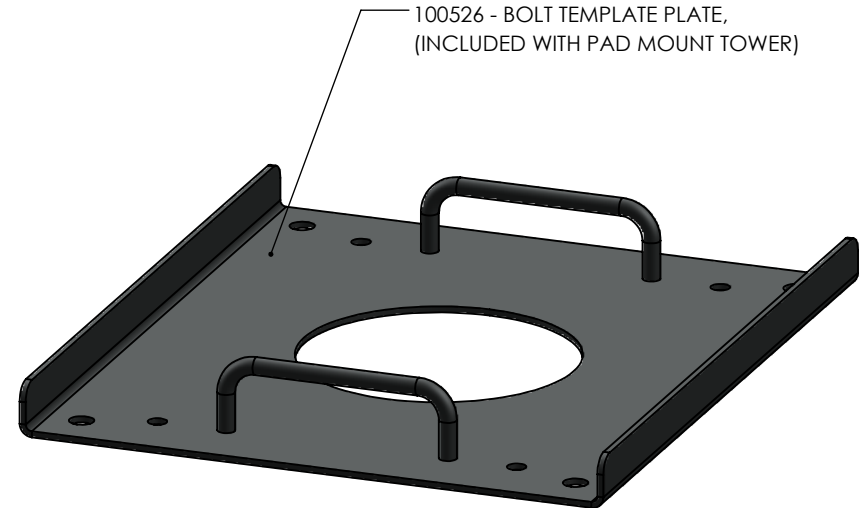

PLEASE NOTE:
CAN USED ALONE FOR DRILLED AND ADHESIVE ANCHORED STUDS
FOR WET SET ANCHORS - USE TOGETHER WITH 100525-TEMPLATE ALIGNMENT SUPPORT.

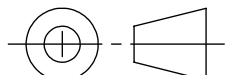
PROPRIETARY & CONFIDENTIAL		UNLESS OTHERWISE SPECIFIED		APPROVALS	NAME	DATE	 BLUE STAR TOWERS TITLE: TEMPLATE ALIGNMENT SUPPORT	
THE INFORMATION CONTAINED IN THIS DRAWING IS THE SOLE PROPERTY OF BLUE STAR TOWERS, LLC. ANY REPRODUCTION WITHOUT WRITTEN CONSENT IS PROHIBITED.		.X..... ±.030		DRAWN BY	BJH	11/16/2022		
		.XX..... ±.020		CHECKED BY				
THIRD ANGLE PROJECTION		.XXX..... ±.010		ENG APPR.			SIZE: B DRAWING NO. 100525 REV. A	
		.XXX..... ±.005		INTERPRET PER ASME Y14.5-2009		WEIGHT: SHEET: 3 OF 3		
		ANGULAR..... ± 1°		SCALE: 1:10				
		FINISH..... 125RA		DO NOT SCALE DRAWING				

8 7 6 5 4 3 2 1